

UNI-SPRAY QUIK-CHANGE NOZZLE TIP

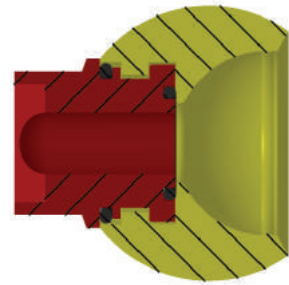
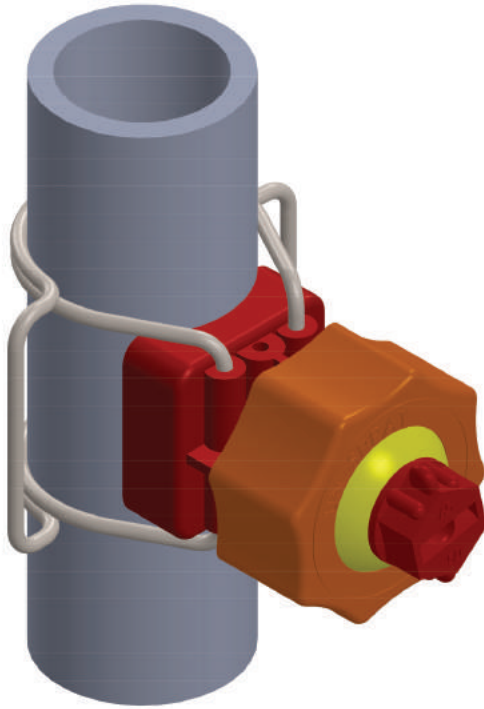

The “Quik-Change” Nozzle Tip is installed with a bayonet mount, and a simple 90° twist is all it takes to lock it into the ball. It is O-Ring sealed at the bottom and lip sealed at the top to prevent the mounting slots and tabs from becoming contaminated and difficult to disassemble.

The exterior dimensions and contours of the ball are identical to our standard Adjustable Nozzle Tips, so the full range of adjustment is still available. However, the tip length has been shortened from that of our standard tips, providing even greater clearance between the spray nozzle and your product.

FEATURES

- Inexpensive
- Low profile design
- Corrosion resistant
- Impervious to most chemicals
- Heat resistance to 130° C
- Injection-molded from custom-blended polypropylene or Kynar
- Available with threaded connections in 1/8", 1/4", 3/8" and BSPT threads
- Convenient replacement process to reduce maintenance downtime

Mark 4 Quik-Change Nozzle Base

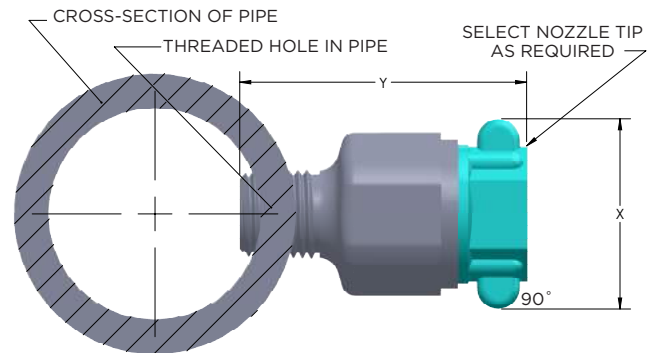

MAJOR DIMENSIONS

Connection	Y	X	Colour
1/8" Thread	40,9 mm	28,5 mm	Grey
1/4" Thread	40,9 mm	28,5 mm	Grey
3/8" Thread	40,9 mm	28,5 mm	Grey
1/2" Thread	40,9 mm	28,5 mm	Grey

