

Paper Trimming Nozzles

CMP-T/CTM/CM

Solid Stream

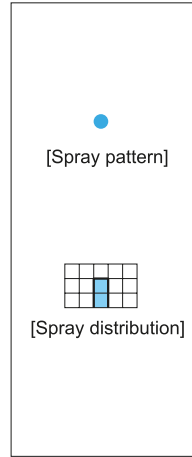

[Features]

- Extra fine and clear non-turbulent solid stream nozzles with high impact cutting force.

[Standard pressure]

1 MPa

[Applications]

- Trimming: Papermaking
- Cutting: Timber, food
- Others: Cleaning of precision machine parts, injection of chemicals, deburring, foaming of beer (jet foamer)

CMP-T series

	CMP-T series (with alumina ceramic orifice inserted)
Structure	<ul style="list-style-type: none"> • High-purity alumina ceramic orifice is inserted into a sleeve of strong engineering plastics. • Comprises two parts: Nozzle and strainer. Worn-out nozzles can be replaced separately.
Material	<ul style="list-style-type: none"> • Nozzle orifice: 99% alumina • Sleeve: PA • Metal parts: S303 • O-ring: NBR
Mass	<ul style="list-style-type: none"> • Complete assemblies: 47 g • Nozzle only: 40 g

Complete assemblies

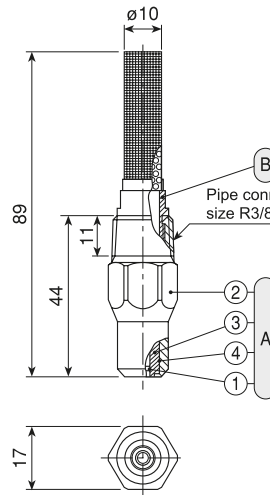

Nozzle only

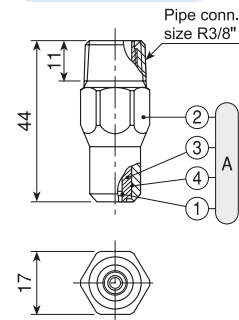

[Note] Appearance and dimensions may differ slightly depending on materials and nozzle codes.

Ⓐ **Nozzle** (①99% Alumina orifice ②Nozzle body ③Sleeve ④O-ring [NBR])
 Ⓑ **Strainer**

CTM series

	CTM series (with tungsten carbide orifice inserted)
Structure	<ul style="list-style-type: none"> • Includes a tungsten carbide orifice in the tip of the nozzle. • Comprises two parts: Nozzle and adaptor-strainer. Worn-out nozzles can be replaced separately.
Material	<ul style="list-style-type: none"> • Nozzle orifice: tungsten carbide • Metal parts: S303

[Complete assemblies]

Orifice diameter code	Nozzle thread size	Dimensions (mm)						Mass (g)
		L2	L3	H1	H2	øD	N2	
ø0.2-ø0.9	R1/8	54	92	10	17	10	11	39
ø1.0-ø1.5	R1/4	52	90	14	17	10	11	47

Adaptor thread size (pipe connection size) is R3/8".

[Nozzle only]

Orifice diameter code	Nozzle thread size	Dimensions (mm)			Mass (g)
		L1	H1	N1	
ø0.2-ø0.9	R1/8	40	10	7	16.5
ø1.0-ø1.5	R1/4	40	14	10.5	30

[Note] Appearance and dimensions may differ slightly depending on materials and nozzle codes.

Complete assemblies

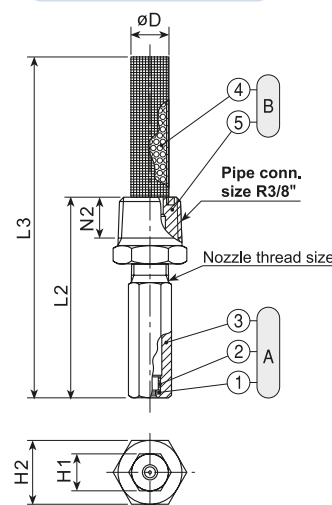

Nozzle only

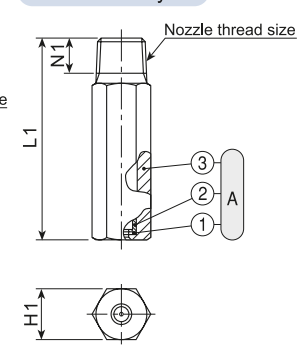

Ⓐ **Nozzle** (①Tungsten carbide orifice ②Sleeve ③Nozzle body)
 Ⓑ **Strainer** (④Strainer ⑤Adaptor)

[Note] Adaptor and strainer are NOT detachable.

CM series

CM series (with ceramic orifice inserted)	
Structure	<ul style="list-style-type: none"> Includes a ceramic orifice in the tip of the nozzle. Comprises two parts: Nozzle and adaptor-strainer. Worn-out nozzles can be replaced separately.
Material	<ul style="list-style-type: none"> Nozzle orifice: ceramic Metal parts: S303

[Complete assemblies]

Orifice diameter code	Nozzle thread size	Dimensions (mm)						Mass (g)
		L2	L3	H1	H2	øD	N2	
ø0.1-ø0.9	R1/8	54	92	10	17	10	11	39
ø1.0-ø1.5	R1/4	52	90	14	17	10	11	47

Adaptor thread size (pipe connection size) is R3/8".

[Nozzle only]

Orifice diameter code	Nozzle thread size	Dimensions (mm)			Mass (g)
		L1	H1	N2	
ø0.1-ø0.9	R1/8	40	10	7	16.5
ø1.0-ø1.5	R1/4	40	14	10.5	30

[Note] Appearance and dimensions may differ slightly depending on materials and nozzle codes.

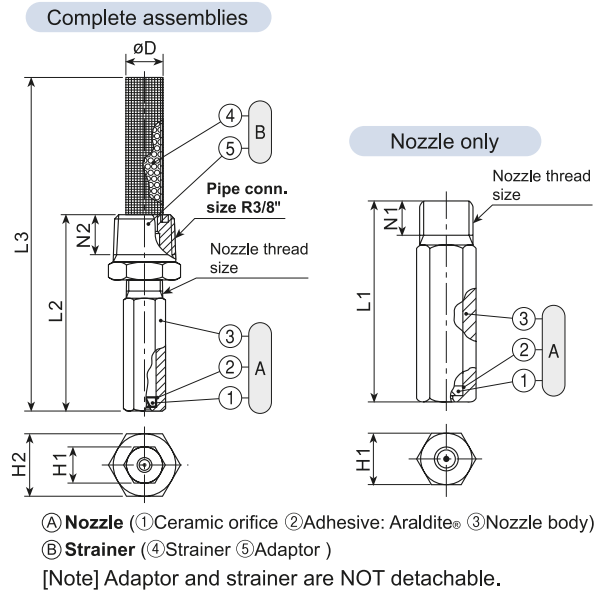

Solid Stream

Orifice diameter code	CMP-T	CTM	CM	Spray capacity (ℓ/min)						Strainer mesh size
				0.5 MPa	1 MPa	2 MPa	3 MPa	4 MPa	5 MPa	
				ø0.1			●	0.011	0.016	
ø0.15			●	0.03	0.04	0.05	0.06	0.07	0.08	200
ø0.2		●	●	0.05	0.06	0.09	0.11	0.12	0.14	200
ø0.25		●	●	0.07	0.10	0.14	0.17	0.19	0.21	200
ø0.3	●	●	●	0.10	0.14	0.19	0.23	0.27	0.30	150
ø0.4	●	●	●	0.17	0.24	0.34	0.41	0.47	0.52	150
ø0.5	●	●	●	0.25	0.35	0.49	0.60	0.68	0.76	80
ø0.6	●	●	●	0.36	0.51	0.71	0.86	0.99	1.10	80
ø0.7	●	●	●	0.49	0.69	0.96	1.17	1.34	1.49	50
ø0.8	●	●	●	0.65	0.90	1.26	1.53	1.75	1.95	50
ø0.9	●	●	●	0.78	1.09	1.52	1.84	2.11	2.35	50
ø1.0	●	●	●	0.97	1.34	1.88	2.28	2.61	2.91	50
ø1.1		●	●	1.17	1.63	2.27	2.75	3.16	3.51	50
ø1.2		●	●	1.39	1.94	2.70	3.28	3.76	4.18	50
ø1.3		●	●	1.63	2.27	3.17	3.85	4.41	4.91	50
ø1.4		●	●	1.89	2.64	3.68	4.46	5.12	5.69	50
ø1.5		●	●	2.17	3.03	4.22	5.12	5.88	6.54	50

●: Available with strainer

[Note] The above nozzles are manufactured for specific orifice diameters, therefore spray capacity is not guaranteed.

■ CMP-T series (with alumina ceramic orifice inserted)

How to order

Please inquire or order for a specific nozzle using this coding system.

① Complete assemblies

<Example> 3/8M CMP ø0.3T S303W

3/8M CMP ø0.3 T S303W

Orifice diameter code
ø0.3~ ø1.0

② Nozzle only

<Example> 3/8M CMP ø0.3T S303

3/8M CMP ø0.3 T S303

Orifice diameter code
ø0.3~ ø1.0

■ CTM series (with tungsten carbide orifice inserted)

How to order

Please inquire or order for a specific nozzle using this coding system.

① Complete assemblies

<Example> 3/8MCTM ø0.2 S303W (PM-Strainer ø10)

3/8M CTM ø0.2 S303W (PM-Strainer ø10)

Orifice diameter code
ø0.2~ ø1.5

② Nozzle only

<Example> 1/8M CTMP ø0.2 S303

1/8M CTMP ø0.2 S303

Nozzle thread size*
1/8M 1/4M
Orifice diameter code
ø0.2~ ø1.5

■ CM series (with ceramic orifice inserted)

How to order

Please inquire or order for a specific nozzle using this coding system.

① Complete assemblies

<Example> 3/8MCM ø0.1 S303W (PM-Strainer ø10)

3/8M CM ø0.1 S303 W (PM-Strainer ø10)

Orifice diameter code
ø0.1~ ø1.5
Material
S303

② Nozzle only

<Example> 1/8M CMP ø0.1 S303

1/8M CMP ø0.1 S303

Nozzle thread size*
1/8M 1/4M
Orifice diameter code
ø0.1~ ø1.5
Material
S303

*"M" indicates male thread ("R" of the ISO standard) and "F" indicates female thread ("Rc" of the ISO standard), e.g. 1/8M = R1/8".